

**UPS  
Uninterruptible Power Supply  
Adira (10 kVA, 20 kVA 31-phase)  
Battery Bank**

**Operating Manual V. 1.1**



Article numbers: ACX31ADS10K00000  
ACX31ADS20K00000

## Legal notice



© by EFFEKTA Regeltechnik GmbH

**EFFEKTA Regeltechnik GmbH**, 78628 Rottweil, retains the copyright to this documentation.

This documentation is solely intended for the operator and his staff. The content of this documentation (texts, figures, drawings, graphics, plans, etc.) may not be copied or distributed in part or in full without our consent in writing, nor can it be used without authorisation for competitive purposes or given or made accessible to third parties.

EFFEKTA Regeltechnik GmbH

Rheinwaldstraße 34  
D – 78628 Rottweil  
Germany

Phone: + 49 (0) 74 1 / /1 74 51 - 0  
Fax: + 49 (0) 74 1 / /1 74 51 - 22  
E-mail: [ups@effekta.com](mailto:ups@effekta.com)  
Internet: [www.effekta.com](http://www.effekta.com)

Manual:	Operating manual
Language:	English
Release date:	10/2013

We reserve the right to make changes to the design and the system that will improve the system, the production process or the product.

# Table of Contents

- 1. Introduction ..... 5**
  - 1.1 Introduction ..... 5
  - 1.2 Validity ..... 6
  - 1.3 Storage ..... 6
  - 1.4 Symbols in this Manual ..... 6
  - 1.5 Information Obligation ..... 10
  - 1.6 Warranty Conditions ..... 10
  - 1.7 Transport and Storage ..... 12
  - 1.8 Positioning ..... 13
- 2. Safety Instructions ..... 14**
  - 2.1 Introduction ..... 14
  - 2.2 Proper Use ..... 14
  - 2.3 Avoiding Personal Injury / Property Damage ..... 15
  - 2.4 Protecting the Environment ..... 15
  - 2.5 Connection ..... 16
  - 2.6 Operation ..... 17
  - 2.7 Working with Accumulators ..... 17
  - 2.8 Maintenance, Service and Malfunctions ..... 18
- 3. Device description of the UPS ..... 19**
  - 3.1 Elements on the front of the device ..... 20
  - 3.2 Elements on the back of the device ..... 25
  - 3.3 Components ..... 29
- 4. Storage and Unpacking ..... 32**
  - 4.1 Storage of the UPS ..... 32
  - 4.2 Moving the UPS to the installation site ..... 32
  - 4.3 Unpacking of the device ..... 32
- 5. System Description ..... 36**
- 6. UPS Installation and Connection ..... 38**
  - 6.1 Notes on the installation ..... 38
  - 6.2 Connecting the UPS ..... 39
  - 6.3 Communication port of the UPS ..... 40
  - 6.4 Connection sequence ..... 40
  - 6.5 Configuration of the EPO-port ..... 41
  - 6.6 Operating procedure for the connection with an external battery ..... 42
  - 6.7 Feedback protection ..... 43

<b>7. Operation .....</b>	<b>45</b>
7.1 Operation of the UPS .....	45
7.2 UPS operating instructions .....	50
7.3 Menu .....	54
<b>8. Troubleshooting.....</b>	<b>66</b>
8.1 Troubleshooting according to warning indication .....	66
<b>9. Software.....</b>	<b>69</b>
<b>10. Maintenance and Service.....</b>	<b>70</b>
10.1 Measuring the backup-time (support time).....	70
10.2 Replacing the accumulators .....	71
10.3 Service-Log.....	72
10.4 Service-Hotline.....	73
10.5 Maintenance and service contracts .....	73
<b>11. Technical Data.....</b>	<b>74</b>
<b>12. Scope of Delivery / (Optional) Accessories .....</b>	<b>76</b>
12.2 Wearing parts list.....	77
<b>13. Conformity Declarations .....</b>	<b>78</b>
13.1 Adira 3/1 10kVA .....	78
13.2 Adira 3/1 20kVA .....	79

# 1. Introduction

## 1.1 Introduction

Dear Operator,

You are about to operate an uninterruptible power supply.

This operating manual should provide you with support for working responsibly and basic information about the uninterruptible power supply, namely how it operates, its application and what you should do in the event of malfunctioning. Furthermore, this operating manual contains instructions for the transport and storage as well as the handling and installation of the uninterruptible power supply.

The plan guidelines in this operating manual only relate to special requirements for the uninterruptible power supply. During installation, make sure you follow the national and local requirements for electrical installations.

The content of this device description may change due to technological progress. We have tried to present the content correctly and clearly. If, however, we have made errors, we would be grateful for information about this.

We do not assume any liability for errors in this operating manual or any consequences resulting thereof.

The uninterruptible power supply is intended to protect sensitive electronic systems from interferences that could occur due to bad electric quality or grid failures.

**Please read this operating manual carefully and take note particularly of the safety instructions!**

If you have questions about the device, the technical supervisor in your company or our employees will be glad to help you.

Your  
EFFEKTA Regeltechnik GmbH

## 1.2 Validity

The descriptions in this operating manual relate solely to the **uninterruptible power supply**



defined in the technical data as a whole or as it refers to modules, components and individual parts that were developed and built by **EFFEKTA Regeltechnik GmbH**.

(★ 11. Technical Data)

## 1.3 Storage

This operating manual for the device must be stored in the vicinity of the device at all times so it is immediately available if need be.

## 1.4 Symbols in this Manual

The abbreviation UPS in this manual stands for uninterruptible power supply.

- Read this documentation carefully and make yourself familiar with the product before using it.
- Store this operating manual in an easily accessible place to refer to it if necessary.
- Please pass this operating manual on to later users of the product.

### 1.4.1 Danger warning levels



---

**DANGER!**

---

Text that is marked with **DANGER!** provides a warning about dangers. If accident prevention measures are not taken, these dangers may result in serious (irreversible) injuries or even death!

---

---

## WARNING!



Text that is marked with **WARNING!** provides a warning about hazards. If accident prevention measures are not taken, these hazards may result in serious (irreversible) injuries or even death!

---

---

## CAUTION!



Text that is marked with **CAUTION!** provides a warning about hazards. If accident prevention measures are not taken, these dangerous situations can lead to slight or medium reversible injuries.

---

---

## ATTENTION!

Text that is marked with **ATTENTION!** contains very important instructions for situations that, if accident prevention measures are not taken, may result in damage to the product and / or its functions or an object in its vicinity.

---



This symbol indicates text that contains important instructions / comments or tips.

---

### 1.4.2 Warning information

#### 1.4.2.1 Warning about danger spots



General warning about danger spots!

#### 1.4.2.2 Specific warning



Warning about dangerous electrical voltage!



Warning about proper handling of accumulators!

### 1.4.3 Instruction symbols



Take note of the provided documentation and/or instructions!



Disconnect before work!



1.4.4 General symbols

- This dot marks descriptions of activities that you should carry out.
- This dash marks specification lists.
- ⇒ This arrow marks a cross reference.  
 If a cross reference to another chapter is necessary in the text, this is shortened for clarity.  
 Example: ⇒ OM, 2 Safety Instructions  
 This means: See Operating Manual, Chapter 2 Safety Instructions.  
 If the cross reference refers to a page, figure or position number, this information is added at the end of the cross reference.  
 Example: ⇒ Fig. 4 - 4, Pos. 1  
 This means: See position number 1 in figure 4 in Chapter 4 of this manual.
- (3) Numbers in brackets refer to the positions in the figures.



Identifies instructions for recycling.



Identifies components that are subject to the Electronic Scrap Regulation.



Identifies components or parts that must be disposed of. Do not throw these into the household waste.



Requirement that must be fulfilled:

- ✓ The DC circuit breaker is on "OFF".

## 1.5 Information Obligation

This operating manual must be read, understood and all its points must be taken note of by all persons that are responsible for the

- Operation
- Cleaning and
- Disposal

of this device.

**EFFEKTA Regeltechnik GmbH is not liable for damage incurred or caused by staff who have not been trained or who have been insufficiently trained!**

## 1.6 Warranty Conditions

The receipt of delivery is considered as the record for the initial purchase and should be kept in a safe place. It will be necessary for making use of the warranty. If the product is passed on to another user, he has the right to the warranty for the remainder of the warranty period. The purchase receipt as well as this declaration should also be given to the new owner if the device is passed on.

We guarantee that this device, upon delivery, is in a functional state and technically conforms to the descriptions in the appended documentation.

The warranty period for special devices corresponds to the minimum periods stipulated by law.

The warranty ceases to apply in the following cases:

In the event of defects caused by: freight damage, accident, natural catastrophes, misuse, vandalism, improper use, defective maintenance or incorrect repair by third parties.

- In the event of changes, unauthorised intervention, incorrect operation, another device or accessories, false installation or other modifications not approved by us.
- Improper use such as plugging the device into unsuitable energy sources, attempts to overload the UPS, use in an unsuitable environment, etc.
- In the event of failure to follow instructions in the provided documentation.

- In the event that the product is incompatible due to possible technical innovations or regulations that occur after the purchase.
- In the event of incompatibility or malfunctioning that was caused by product components we did not install.
- In the event of developments that are related to the normal aging process of the product (wear parts).
- In the event of defects that were caused by external fixtures.

The warranty period for replaced and/or repaired parts as part of this warranty expires together with the original warranty for the product.

Devices that are supplied without accessories are replaced without accessories. The return of the device is only accepted if this is done in the original packaging.

Incurred transport costs are generally not included in the warranty.

You shall bear the cost of repair and exchange, and the company is not liable for damage, whether directly, unintentionally, specifically, or for subsequent damage, even if it was caused by negligence or other errors.

**EFFEKTA Regeltechnik GmbH** does not provide either explicit or implicit warranties related to this device and its quality, performance, saleability or suitability for a certain purpose. In some countries, the exclusion of implicit warranties is not permitted by law. In this case, the validity of all explicit and implicit warranties is limited to the warranty period. With the expiration of these periods, all warranties lose their validity. In some countries, a limitation of the validity period of implicit warranties is not permitted by law so that the aforementioned limitation does not take effect.

### 1.6.1 Limitation of liability

Claims to damage compensation are excluded unless they involve intent or gross negligence by **EFFEKTA Regeltechnik GmbH** or its employees. This does not affect liability according to the Product Liability Act. Under no circumstances are we liable for:

- Claims that third parties make against you due to losses or damage.
- Loss or damage of your records or data or the costs of recovering this data.
- Economic subsequent damage (including lost profits or savings) or concomitant damage, including in the event that we were informed of the possibility of such damage.

Under no circumstances is **EFFEKTA Regeltechnik GmbH** responsible for any accidental, indirect, specific, subsequent or other damage of any kind (including, without any limitation, damage related to a loss of profits, interruption of business, loss of business information, or any other losses) that result from use of the device or are connected with the device whether they are based on the contract, damage compensation, negligence, strict liability or other claims, even if **EFFEKTA Regeltechnik GmbH** was informed about the possibility of such damage in advance. This exemption also includes any liability that can result from the claims of third parties against the initial purchaser.

In some countries, the exemption or the limitation of concomitant or subsequent damage is not permitted by law so that the aforementioned declaration does not enter into force.

## 1.7 Transport and Storage

The UPS may only be transported to the intended location in the original packaging. The same applies to moves or returns.

The packaging plays no role as fall protection, so all fallen devices must be checked by **EFFEKTA Regeltechnik GmbH** before commissioning.

The device may not be transported or stored upside-down.

## 1.8 Positioning

# WARNING!

**Do not install in an area in which combustible vapours arise e.g. from petrol tanks, engine compartments, etc.**

The UPS is designed for operation in ventilated rooms with an ambient temperature of 0° to 40°C.

If the UPS is exposed to severe and quick temperature changes, there is danger of condensation. Before you take additional steps, an acclimatization period of at least 2 hours is to be observed.

Never place or operate the device in a moist environment. Keep liquids away from the device.

The UPS may not be placed in the vicinity of heat sources.

The UPS may only be set-up in a vertical position and on castors.

Ensure that the back side and the front side of the device are at least 10 cm from other objects for ventilation in order to prevent trapped air and too much warming. Make sure that the air openings cannot be covered, e.g. through sucked-in paper, material, etc.

---

## 2. Safety Instructions

### 2.1 Introduction

---



The UPS is a device that has been produced according to the rules and regulations of technology for an uninterruptible power supply.

The device is safe when used properly and under consideration of the safety requirements and instructions provided in this operating manual.

---

### 2.2 Proper Use

---

The UPS and its related components may only be used for purposes in accordance with its design – to provide a short-term supply for electrical devices (230 V AC) with the nominal power not exceeding the total.

Any other use is considered improper and can lead to personal injury or damage to the device!



Improper Use:

The device is not designed for use in

- **explosive,**
- **dusty,**
- **radioactive or**
- **biologically or chemically contaminated atmospheres!**

---

# ATTENTION!

**This class A equipment. This equipment can cause radio interference in residential areas. In this case, the operating company may be requested to take appropriate measures!**

---

## 2.3 Avoiding Personal Injury / Property Damage

- Please read this operating manual carefully to familiarise yourself with the device.
- In particular, take note of the information regarding the installation and commissioning of the device.
- Only operate the product in an appropriate and proper way and within the parameters stated in the technical data.
- Only perform maintenance and service work that is described in the documentation. Observe the required steps. Only use original replacement parts from **EFFEKTA Regeltechnik GmbH**

## 2.4 Protecting the Environment

- Send the product back to **EFFEKTA Regeltechnik GmbH** after the end of its service life. We will ensure environmentally friendly disposal.

## 2.5 Connection

# DANGER!



The UPS is connected via the connection terminals on the back of the device. The PE (protective earth conductor) must be connected without fail. The device may not be used without the PE under any circumstances.

Keep the cable length as short as possible.



During generator operations the pole-correct connection of the UPS must be ensured.

For the connection of the UPS with the electricity grid, only a power cable that is VDE-approved and labelled CE may be used.

For the connection of the appliances with the UPS only a power cable that is VDE-approved and labelled CE may be used.

The safeguarding of any appliance must always be immediately in front of an appliance and may never be done centrally in front of the UPS.

Never operate any household devices or tools like e. g. fan heaters, vacuum cleaners, electric drills, toasters, etc. with the UPS.

Do not connect any appliance to the UPS that could overload the device (e.g. laser printer).

Keep the connecting cables as short as possible and always install them correctly. Avoid hazards to the cable like tripping, crushing, clipping etc.



## 2.6 Operation

Before the appliances are connected to the outlet, the basic configuration must be completed. Especially the output voltage is of high importance regarding the appliances.

The UPS-system contains an energy storage (accumulators). This means that the outlet can be current-carrying even when the UPS is not connected to the mains input terminal.

To completely shut-down the UPS, first disconnect the mains connection and then hold the "OFF" button pressed for more than 3 seconds. Wait for the UPS to turn off, before disconnecting the power connection (feeder cable between the UPS and the appliance). Ensure that no liquids or foreign matter enters the UPS. Avoid a constant load of more than 80% on the output to protect the UPS. The displayed output load should only be taken as a reference point, separate measuring is necessary to determine the exact output load.

## 2.7 Working with Accumulators

---

**DANGER!**

---

**Attention – Danger of electric shocks and burns**

Accumulators can cause electric shocks and have a high short-circuit current, which can cause burns.

Unauthorized persons should not have access to the accumulators.

Do not place accumulators in the vicinity of heat sources and do not throw them into a fire. Explosion hazard!

Do not open or destroy accumulators. The released electrolyte presents a great danger to health and the environment (chemical burns to skin and eyes, toxic).

---





## WARNING!

- Defective accumulators have to be disposed of in an environmentally compatible manner.

Never dispose of accumulators with regular household waste.

Local disposal regulations must be observed.

## 2.8

### Maintenance, Service and Malfunctions

## DANGER!



Attention – Danger of electric shocks.

Even after switching off the supply with the power button or after disconnecting the accumulator feed respectively, parts of the UPS can still carry high voltages.

## ATTENTION!

Only trained electricians with sufficient knowledge of the required safety regulations may perform work on accumulators or supervise such work tasks.

Unauthorized persons should not have access to the accumulators.

The following precautions must be taken, when working on the UPS or the accumulators:

- Remove wrist watches, rings and other metallic objects;
- Use only isolated tools that comply with electrotechnical regulations;
- Wear personal protective equipment (safety glasses, gloves, face shield, etc.);
- The UPS may not be disassembled.

### 3. Device description of the UPS

This manual shall provide basic information about one-phase UPS-system of the Adira series, like the mode of operation, utilization of the different functions and what to do in case of malfunctions. In addition, this operating manual contains instructions for the proper transportation and storage, as well as for the handling and installation of the UPS-equipment.

The planning guidelines in this manual refer only to the specific requirements of UPS-systems. National and regional regulations for electrical installations have to be adhered to, when installing the system. The content of this device description may change, due to technological developments. We have made every effort to ensure that all content is accurate and presented in a clear and comprehensible manner. In case of any errors, we are grateful for advice and suggestions.

We do not assume any liability for any errors in this manual or any consequences resulting thereof.

The UPS-system (uninterruptible power supply) is designed to protect sensitive electronic equipment like computers, work stations, electronic cash registers, operations critical instruments, telecommunication systems, process controllers, etc. from interferences that can result from poor power quality or mains failures. Sensitive equipment of this sort needs comprehensive protection from all electrical interference. These may either be external interferences (like e.g. lightning, disruption of operations) or interferences from other devices in its vicinity (e.g. engines, air-conditioning, processing machines, welding facilities, or the like).

Power interferences can be summarized as follows:

- rapid or slow voltage peaks or fluctuations;
- mains failure;
- power overlaps or transients

The UPS-system monitors the above mentioned grid parameters and protects all connected appliances through appropriate countermeasures (e. g. switching to bypass mode when temporary over- or under-voltage of the grid is detected, to protect the end device).

### 3.1 Elements on the front of the device

On the front side of the device are all operating and display elements necessary for the normal operation of the UPS.



Fig. 3-1 Frontal view – UPS / Control panel (Display)

### 3.1.1 LCD-Display

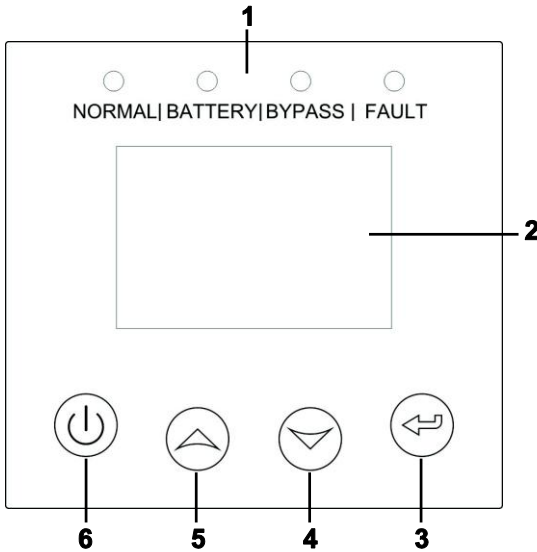

- 1 Status-Display
- 2 LCD-Display
- 3 "Select"-button
- 4 "Menu Down/Next"-button
- 5 "Menu Up/ Back"-button
- 6 "ON/ OFF"-button

Fig. 3-2 Control panel

The back-lighting of the LCD-Display changes its colour depending on the device status.

Colour	Meaning
blue	normal operating mode
red	fault mode

Colour	Name	Function
green	Inverter-LED	If it is turned on constantly, it shows that the load current is supplied from utility power or battery via the inverter.
yellow	Battery-LED	If it is turned on constantly, it shows that the UPS is in battery mode, and the load current is from battery via the inverter.
yellow	Bypass-LED	If it is turned on constantly, it shows that the auto-bypass is activated.
		If it is flashing, it shows that the auto-bypass is deactivated.
red	Fault-LED	If it is turned on constantly, it shows that the UPS is in fault mode.
		If it is flashing, it shows that the UPS is in warning status.

3.1.2 LED action summary

No	Status	LED Display			
		normal LED green	battery LED yellow	bypass LED yellow	Fault LED red
1	power-on mode (activation)	△	△	△	△
2	bypass mode (without output)			★	↑
3	bypass mode (with output)			●	↑
4	line mode (line-mode)	●			↑
5	battery mode	●	●		↑
6	battest mode (battery test mode)	△	△	△	△
7	HE mode (high efficiency mode)	●		●	↑
8	warning	↑	↑	↑	★
9	fault mode			↑	●

Remarks :

●: permanently lit

△: #1-#4 lightened circularly

★: flashing

↑: depended on the fault/warning status of other status

### 3.1.3 Button



Selection

Functions:

- Switching to the next sub-menu:  
By pushing this button for one second you switch to the sub-menu of the currently active menu item.  
**Changes will not be saved!**
- Opening of the current menu items:  
By pushing the button for one second the currently selected menu will be opened.
- Saving Changes:  
By pushing the button for more than one second, you can edit the currently selected menu entry.



Menu down/ next

Functions:

- By pushing the button for about one second you can scroll through the currently active menu.



Menu up/ back

Functions:

- Switching to main menu:  
Push this button for more than one second to switch from the standard display to the main menu.
- Back:  
Push this button for about one second to switch to the next higher menu or to go back step by step.



ON / OFF

Functions:

- By pushing this button you can turn the device on or off.
- If you push this button while you are in the main menu, the display will switch to the standard display.



### 3.2 Elements on the back of the device

---

**DANGER!**



The connecting terminals "UPS-Output" and "Mains-Input" are on mains potential when connected.

However, there can still be a dangerously high voltage on the connecting terminals even while disconnected, due to device-internally loaded capacities.

---



---

As soon as mains input voltage is present, the loading unit is automatically activated. I.e. the internal battery bank is already being charged, even though the UPS has not been switched on.

---

3.2.1 Model 10 kVA 3/1-phase

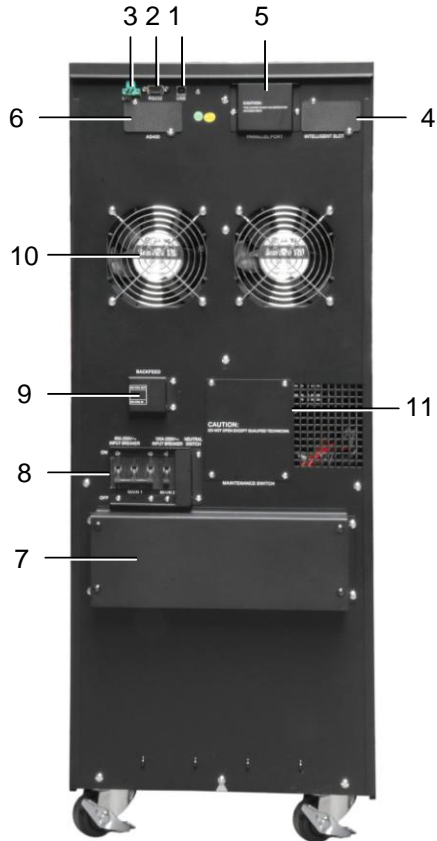

- 1 USB-port
- 2 RS 232
- 3 "EPO"-port
- 4 Communication interface („Intelligent Slot“)
- 5 Parallel port
- 6 AS 400-port
- 7 Connection terminals mains-input and UPS-output
- 8 Circuit Breaker mains-input
- 9 Feedback protection
- 10 Fan
- 11 Bypass switch

Fig. 3-3 Back panel 10 kVA 3/1-phase

3.2.2 Model 20 kVA 3/1-phase

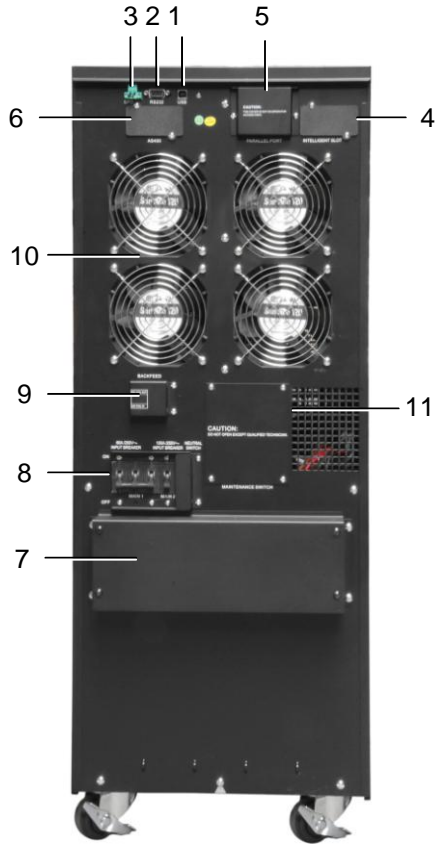

- 1 USB-port
- 2 RS 232
- 3 "EPO"-port
- 4 Communication interface („Intelligent Slot“)
- 5 Parallel port
- 6 AS 400-port
- 7 Connection terminals mains-input and UPS-output
- 8 Circuit Breaker mains-input
- 9 Feedback protection
- 10 Fan
- 11 Bypass switch

Fig. 3-4 Back panel 20 kVA 3/1-phase

### 3.2.3 External battery bank for 10 & 20 kVA 3/1-phase

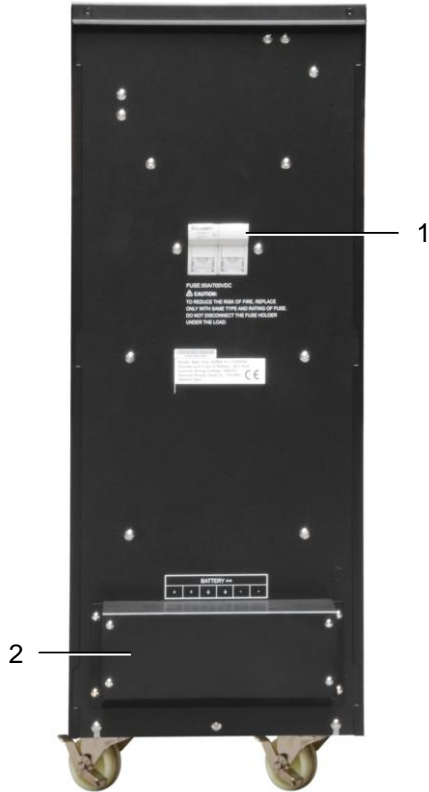

- 1 Fuses
- 2 UPS Connection

Fig. 3-5 Back panel external battery bank for 10 & 20 kVA 3/1-phase

### 3.3 Components

#### 3.3.1 RS232/USB ports

These ports serve to connect the UPS to a PC. A simultaneous use of the USB and the RS232 interface is not possible.

#### 3.3.2 EPO-port

The EPO-port serves for an emergency shut-down of the connected appliances. This function can be used to shut down connected appliances in the case of an emergency.



---

## WARNING!

This circuit has to be separated from high-voltage circuits by reinforced insulation.

---

---

## CAUTION!

The EPO-port may not be connected to circuits that are directly connected with the mains power supply.

Feeders must have reinforced insulation

The load capacity of the EPO-switch must be at least 24 V DC / 20 mA and it must be designed as a special snap-switch without any connection to any other circuit.

The EPO-signal must remain active for at least 20 ms, to ensure proper operation.

---

### 3.3.3 Intelligent Slot

After unscrewing the cover, various additional expansion cards can be installed, e.g. SNMP-card.



*Fig. 3-6 Network port  
(SNMP-mini-slot-card)*

### 3.3.4 AS400

After unscrewing the cover, the AS400 extension card can be installed.

### 3.3.5 Parallel port

This function is not supported.

### 3.3.6 Bypass switch

The manual bypass can be useful if the UPS needs to be deactivated but the connected appliances still have to be supplied with electricity (e.g. UPS failure, malfunctions etc.).

This procedure may only be carried out by a trained electrician authorized by the manufacturer!

### 3.3.7 Port for external battery banks

External battery banks can be connected to the UPS, to increase backup time.

### 3.3.8 UPS connection terminals

Connection terminals to connect appliances and the mains supply input.

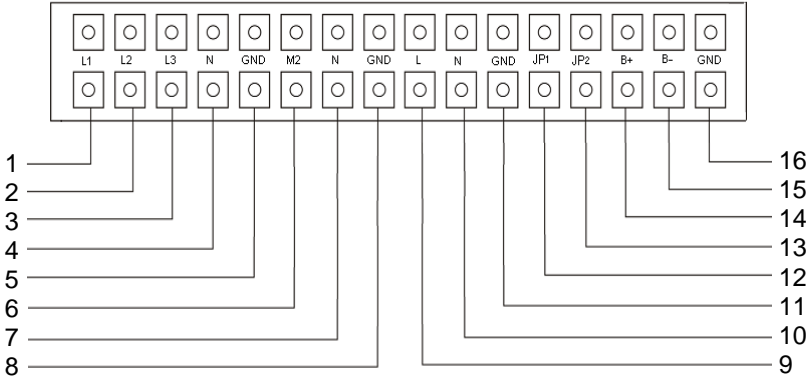

- 9 Terminal supply input L1
- 10 Terminal supply input L2
- 11 Terminal supply input L3
- 12 Terminal supply input N
- 13 Terminal supply input PE
- 14 Terminal Main 2 L (Bypass)
- 15 Terminal Main 2 N (Bypass)
- 16 Terminal Main 2 PE (Bypass)

- 1 Terminal supply output L
- 2 Terminal supply output N
- 3 Terminal supply output PE
- 4 Terminal parallel jumper 1
- 5 Terminal parallel jumper 2
- 6 Terminal ext. Battery +Pol
- 7 Terminal ext. Battery -Pol
- 8 Terminal ext. Battery PE

Fig. 3-7 Connection terminals

**DANGER!**

The protective earth conductor must be connected!

Please always note the specified input voltage on the type plate or in the technical specifications in this operating manual respectively.

### 3.3.9 Fan

Fan to cool the device.

## 4. Storage and Unpacking

### 4.1 Storage of the UPS

In case the device is not being installed immediately, please note the following:

- Always store the device and any accessories in their original packaging.
- The suggested ambience temperature for the storage is between:  
+ 0 °C ... + 40 °C.
- Protect the device and packaging from moisture and liquids.

If the storage period exceeds four months, the UPS and the corresponding battery bank (optional) have to be connected with the mains power supply for approximately 24 hours to avoid a total discharge of the accumulators.

### 4.2 Moving the UPS to the installation site





The UPS is on castors to facilitate moving the device to the installation location after unpacking. However, if the receiving area is far from the installation site, we recommend you to move the UPS by using a pallet jack or a lifter before you start to unpack the UPS.

### 4.3 Unpacking of the device

- At the installation site, the utmost care shall be taken when removing the packaging in order to avoid damaging the equipment. Check all packaging materials to ensure that no items are missing.  
The shipping package contains:
  - A UPS
  - A user manual
  - A USB-cable



Remove the packaging following the sequence illustrated in Fig. 4-1 to Fig. 4-4.

Tools			
	Lifter		Phillips screwdriver
	Scissors		Wrench – Spanner

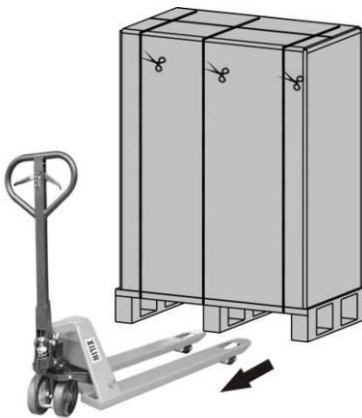

Fig. 4-1 Unpacking – step 1

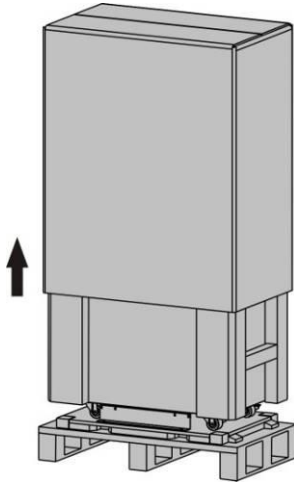

Fig. 4-2 Unpacking – step 2

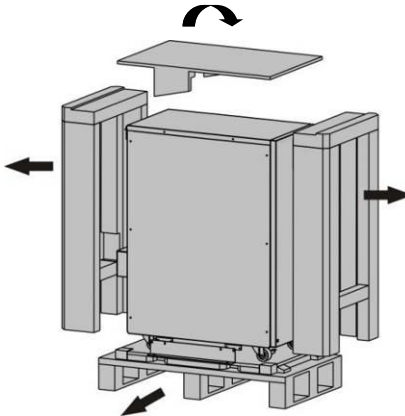

Fig. 4-3 Unpacking – step 3

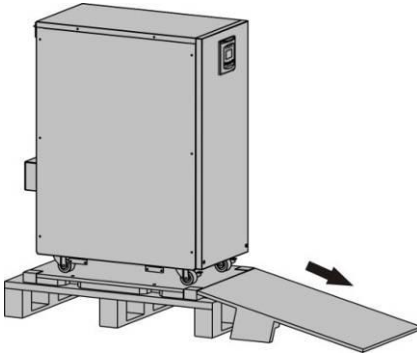

Fig. 4-4 Unpacking – step 4



---

The shipping materials are recyclable. After unpacking, save them for later use or dispose of them appropriately.

---

- Inspect the appearance of the UPS to see if there was any damage incurred during transportation. Do not turn on the unit and notify the carrier and dealer immediately if there is any damage or if any parts are missing.

## 5. System Description

The UPS runs in continuous operation according to the double converter principle. It serves for the processing of the mains current and provides an uninterruptible and interference-free one-phase voltage for operations critical appliances.

In addition to providing power to the appliance, it also maintains the internal accumulators in charged condition. In the case of a mains failure or interference, the UPS continues to provide a clean supply voltage from the UPS-output without interruption. During the backup mode, power is provided from the accumulators.

On-line UPS

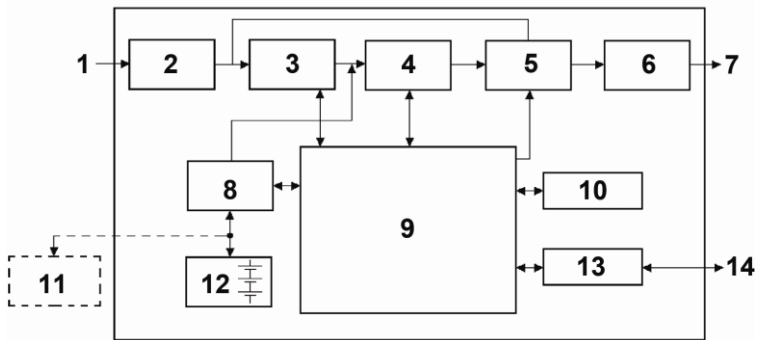

- |                        |  |
|------------------------|--|
| <b>1</b> mains-input   | <b>8</b> voltage inverter              |
| <b>2</b> filter        | <b>9</b> control and monitoring        |
| <b>3</b> rectifier     | <b>10</b> control panel and display    |
| <b>4</b> inverter      | <b>11</b> Ext. battery bank (optional) |
| <b>5</b> bypass-switch | <b>12</b> battery bank                 |
| <b>6</b> filter        | <b>13</b> Interface                    |
| <b>7</b> UPS-output    | <b>14</b> RS232/USB                    |

Fig. 5-1 Block diagram

The block diagram visualizes the individual modules of the device and illustrates their interaction.

If a mains failure continues beyond the backup time of the UPS, the UPS shuts down to avoid a total discharge of the accumulators. As soon as the mains power supply returns, the UPS automatically turns on again, supplies electricity to the appliance and controls the charging of the battery bank.

Prominent performance features of the UPS are:

- No interruption or signal change when the primary mains supply fails.
- Perfect sine-wave voltage on the UPS-output.
- Process controlled bypass mode.
- "Power Factor" correction on the input side (> 0,99).
- LCD-Display for status and operation data display.
- Outstanding performance factor of 0.9.
- Efficient and extensive communication interfaces.
  - USB standard
  - Emergency stop contact "EPO" standard

## 6. UPS Installation and Connection

# ATTENTION!

The system may only be installed and connected by trained authorized electricians in accordance with respective safety rules and regulations!

All requirements listed in the technical specifications concerning ambient and operating conditions must be met, to ensure proper operation of the UPS.

Please note the following during set-up / installation of the UPS:

- Avoid extreme temperatures and humidity.
- Ensure proper vertical set-up, as predefined.
- Allow adequate space for ventilation of the device. Ensure a proper flow channel.
- Pay attention to the system layout. When installing the device in superordinate systems (e.g. machine, switchboard), it has to be ensured, that the UPS is operated within the specified temperature range. In case of a heat build-up in the installation room, it must be removed through adequate powered ventilation.
- The device may only be mounted on castors and a solid, weight bearing and horizontal surface.

### 6.1 Notes on the installation

The UPS must be installed in a well-ventilated environment, far away from water, flammable gas and corrosive agents.

- Ensure that the fans on the front and back side of the UPS are not obstructed by anything. There should be at least half a meter of free space on all sides.
- If the UPS is unpacked in an environment with very low temperatures, there is a danger of condensation and water droplets may form. In this case you have to wait for the UPS to fully dry, inside and out, before you continue with the installation or commission the device, as there may otherwise be a risk of electric shocks.

## 6.2 Connecting the UPS

The installation and wiring must be carried out by professional technicians in accordance with local safety regulations and in adherence to the following instructions.

For safety reasons, turn off the main power switch before you begin with the installation.

- Open the panel of the terminal block at the back of the UPS. Please refer to the system diagram for this task.
- For a 20kVA UPS we recommend to use a cable of 10 mm<sup>2</sup> for the input Main1 and 25 mm<sup>2</sup> for the input Main2 and for the output.
- For a 10kVA UPS we recommend to use a cable of 6 mm<sup>2</sup> for the input Main1 and 10 mm<sup>2</sup> for the input Main2 and for the output.

UPS	Input fuse Main 1	Input fuse Main 2 (Bypass)
10kVA	3x40A	1x63A
20kVA	3x60A	1x100A

# ATTENTION!

Do not use a wall socket as input power source for the UPS, as its nominal current is below the maximal input current of the UPS. The wall socket could burn and get destroyed.

- Connect the input and output cables with the respective input and output terminals.
- The protective earth conductor refers to the cable connection between the parts that consume electric energy and the earth wire. The cable diameter of the protective earth wire should at least have the measurements mentioned above for cables for the individual models and a yellow and green striped wire is to be used.
- Check after completing the installation, if all the wiring is correct.
- Please install the output circuit breaker between the output terminal and the load, and the circuit breaker should be equipped with a fault current protective function, if that is required.
- To connect the load with the UPS, first switch off all loads, then establish the connections and then switch the loads on again, one after the other.

- Regardless whether the UPS is connected to the mains power supply or not, the output of the UPS may still be energized. The parts inside the unit may still carry dangerous voltages, even after the UPS has been turned off. To ensure that the UPS does not emit any electric charge, turn off the UPS and disconnect it from the power supply.
- We recommend that you charge the batteries for at least 24 hours before using the unit. Turn the input-breaker to "ON" after connecting the device; The UPS charges the batteries automatically. You can also put the UPS into operation immediately, without charging the batteries first, however, the backup-time may be below its regular value.

## 6.3 Communication port of the UPS

The UPS is equipped with a convenient communication interface to facilitate the exchange of data with the UPS.

---

### ATTENTION!

---

When connected with a USB-cable, the software can exchange data with the UPS. The software collects detailed information about the status of the power supply from the UPS. In the case of a supply emergency, the software ensures that all data is saved and all appliances are shut down properly.

---

### 6.3.1 SNMP communication port

Optionally, the UPS can be equipped with a SNMP communication port.

## 6.4 Connection sequence

- Connect the UPS with the mains power supply; both, the mains and the UPS must be safely switched-off during this process.
- Before the appliances are connected to the outlet, the basic configuration must be completed.
- Connect the appliance/s with the UPS. Make sure that all appliances are switched-off.



## 6.5 Configuration of the EPO-port

Conductor function	Size of connecting wire
EPO	0,5-1 mm <sup>2</sup>



Leave the EPO-plug installed on the EPO-port of the UPS even if the EPO-function is not needed.

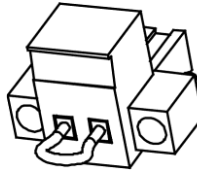

*Fig. 6-1 EPO-plug*



Please see the information regarding the connection of the EPO-contact in **chapter 3.3.3 EPO-port**.

## 6.6 Operating procedure for the connection with an external battery

The nominal DC voltage of the external battery pack is 288VDC. Each battery pack consists of 24 pieces of 12V maintenance-free batteries in series. To achieve a longer back-up time, several battery packs can be connected, but the principle of "same voltage, same type" has to be strictly observed.

The procedure for the installation of the battery bank must be strictly observed, to avoid the risk of an electric shock

- Use only the items listed under accessories. This includes the compatible battery bank and the corresponding connecting cable.
- Ensure that the output voltage of the battery bank is identical with the DC-input voltage of the UPS. Should this not be the case, the units may not be connected with each other under any circumstances.
- You must make sure that the UPS is switched off and that the circuit breaker of the battery bank is removed before connecting the UPS with the battery bank. If the UPS is equipped with an internal battery pack, this pack has to be disconnected from the DC-connectors first.

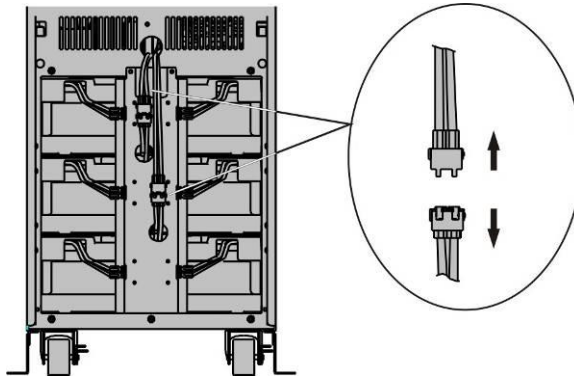

Fig. 6-2 Disconnecting battery pack and UPS

- Connect the external battery pack with the UPS.
- Re-connect the internal battery pack again.
- Install the circuit breakers of the battery bank.
- Switch the input breaker of the UPS to "ON". Now the UPS begins to charge the battery bank.

### 6.7 Feedback protection

On the customer side an additional external insulation device (magnetic contractor, minimum shunt release) must be provided, see Fig. 6-3. This insulation device must be designed to conduct the input voltage of the UPS (see the corresponding table in the general UPS operating manuals).

The insulation device must be installed in the Bypass input line.

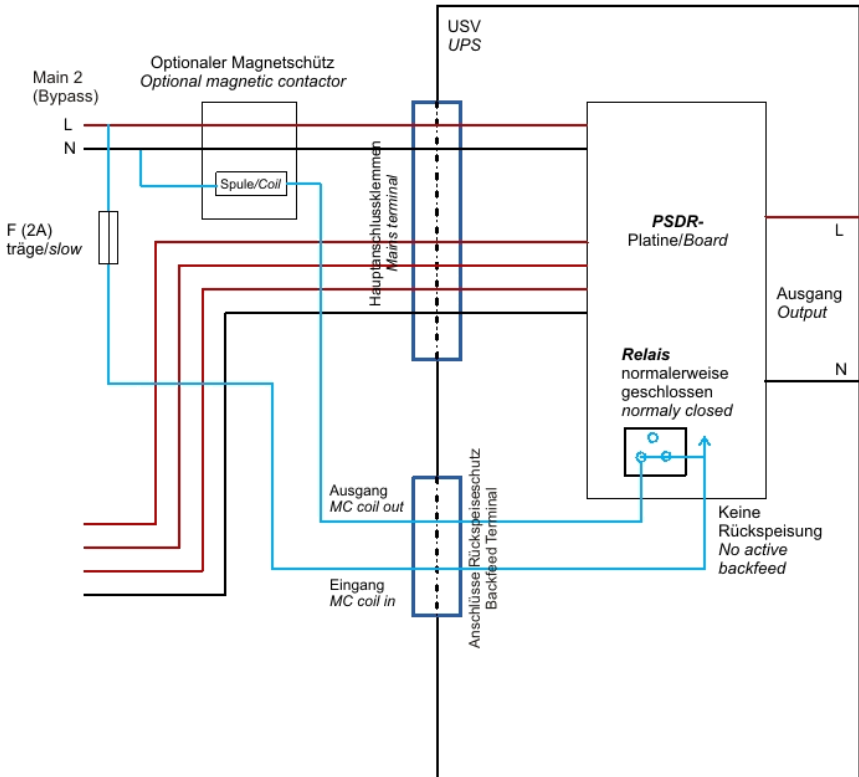

Fig. 6-3 Feedback protection

*Operation*

*If a bypass thyristor is defective (short circuit) and the UPS is operated in double conversion mode (online), the following steps occur:*

*The feedback relay opens and the message "backfeeder" appears in the LCD-Display.*

*Reset*

*To reset the feedback logic, the UPS-system has to be turned off for a few seconds.*

# 7. Operation

## 7.1 Operation of the UPS

The operation of this equipment is characterized by various operating modes and signals.

### 7.1.1 Operating mode

#### line mode

"Line mode" is the regular mains power supply operating mode of the UPS.

The display for line mode looks as follows:

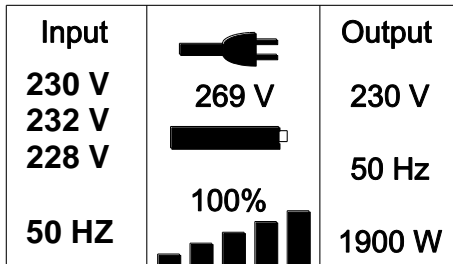

Fig. 7-1 line mode

#### Battery mode

In the event of a mains failure, the UPS switches to battery mode.

The display for battery mode looks as follows:

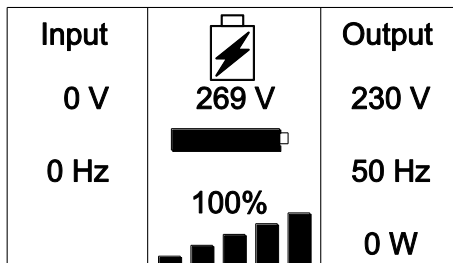

Fig. 7-2 Battery mode

The battery mode is marked by an acoustic signal in four seconds intervals.

Bypass mode

**ATTENTION!**

The UPS has no backup function in bypass mode.

The UPS switches into bypass mode e.g. when there is an inverter problem. The mains input and power output are bypassed via a relay.

The display for bypass mode looks as follows:

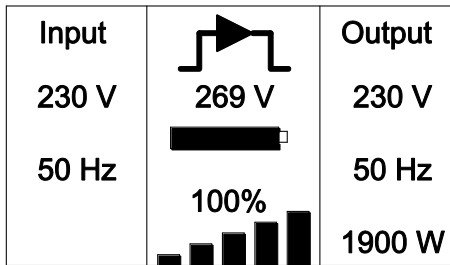

Fig. 7-3 Bypass mode with output

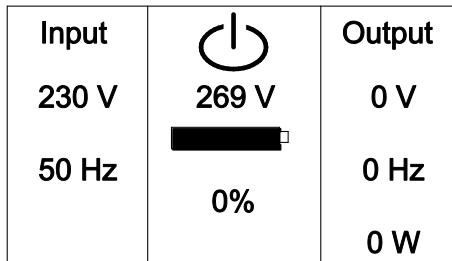

Fig. 7-4 Bypass mode without output

The bypass mode is marked by an acoustic signal in two minutes intervals.

HE-mode (high efficiency)

In HE-mode the UPS is initially in bypass mode. The inverter is only activated in the event of a mains failure. This results in a brief switch-over time in the milli-second range.

The display for HE-mode looks as follows:

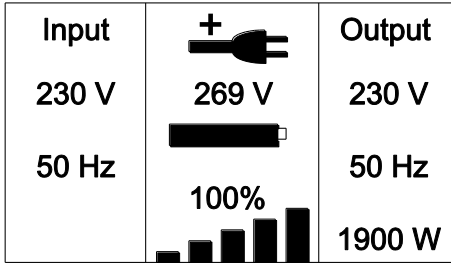

Fig. 7-5 HE-mode

Converter mode

In converter mode the frequencies of the input and output can be configured.

The display for converter mode looks as follows:

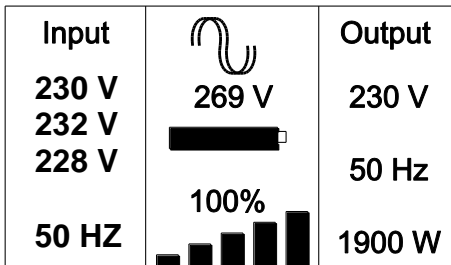

Fig. 7-6 Converter mode

*Warning*

In general, warnings are no fatal faults, but should be fixed as quickly as possible.

The UPS continues to operate when a warning occurs.

If there are any warnings pending at the UPS, the display looks as follows:

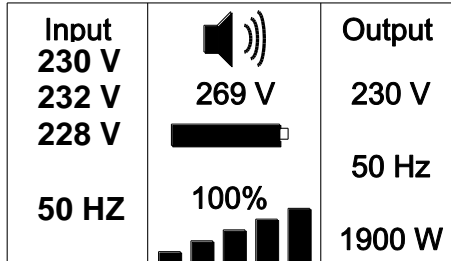

Fig. 7-7 Warning

Fault

A fault alarm signifies a fatal problem.

The UPS signals a fault through an alarm signal and switches either into bypass mode or shuts down, depending on the configuration. The background light of the LCD-Display turns red.

The display for fault mode looks as follows:

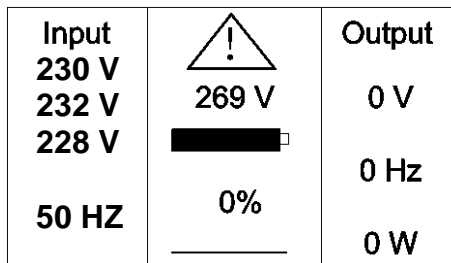

Fig. 7-8 Fault



Other signals

In the event of an overload, the UPS emits an acoustic signal.

The alarm signal sounds twice per second.

The display in the event of an overload looks as follows:

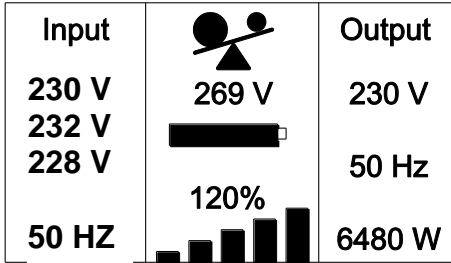

Fig. 7-9 Overload

During a battery test the display looks as follows:

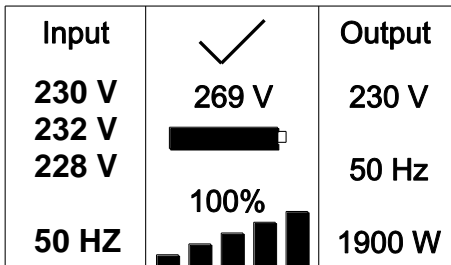

Fig. 7-10 Battery test

If a fault is detected in the battery like e.g. "battery not connected" or "poor battery status", the display looks as follows:

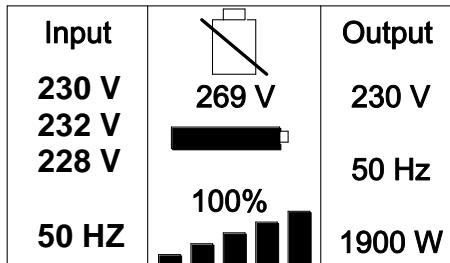

Fig. 7-11 Battery fault

## 7.2 UPS operating instructions

### WARNING!

The operator of the UPS-system must always adhere to the instructions in this operating manual. The operator may only carry out the following measures and must always exercise particular care:

- Use of the operating controls: switching-on, starting and switching-off the UPS.
- Reading of the display messages and interpretation of the acoustic warning signals.
- Triggering the test mode.
- Using the communication interface, whereby the connection to the PC or other systems must already be established for UPS-devices with permanent wiring.

Due to the extensive protective functions the UPS-system performs in relation to the appliance/s, the UPS operates fully automatically. The operator only carries out the switching-on and starting or switching-off of the device. In addition, a data exchange can take place via the communication interface or the SNMP-adaptor, however, this is not absolutely necessary for the general operation of the system.

### 7.2.1 Switching the UPS on / off

#### Turning on the UPS with connected appliances:

- Before turning on the UPS, make sure all appliances are connected correctly.
- Turn on the UPS.  
The UPS is started up, as the fan turns on and the LCD-display shows a welcome message. The UPS conducts a self-test.
- Press the "ON / OFF" button for more than one second until an acoustic signal sounds.  
The UPS is now turned on. A few seconds later the UPS will switch to regular operating mode and is now ready for operation.
- If a fault is present at the UPS, it switches to battery mode and all outputs are deactivated.

#### Turning on the UPS without connected appliances:

- Check all connections before turning on the UPS.
- Turn on the UPS.  
The UPS is started up, as the fan turns on and the LCD-display shows a welcome message. The UPS conducts a self-test.
- Press the "ON / OFF" button for more than one second until an acoustic signal sounds. The UPS is turned on after this procedure.

#### Turning-off the UPS

- Push the "ON / OFF" button for more than three seconds. The system switches into bypass mode. Disconnect the UPS from the mains input, to switch it off completely.

### 7.2.2 UPS menu structure

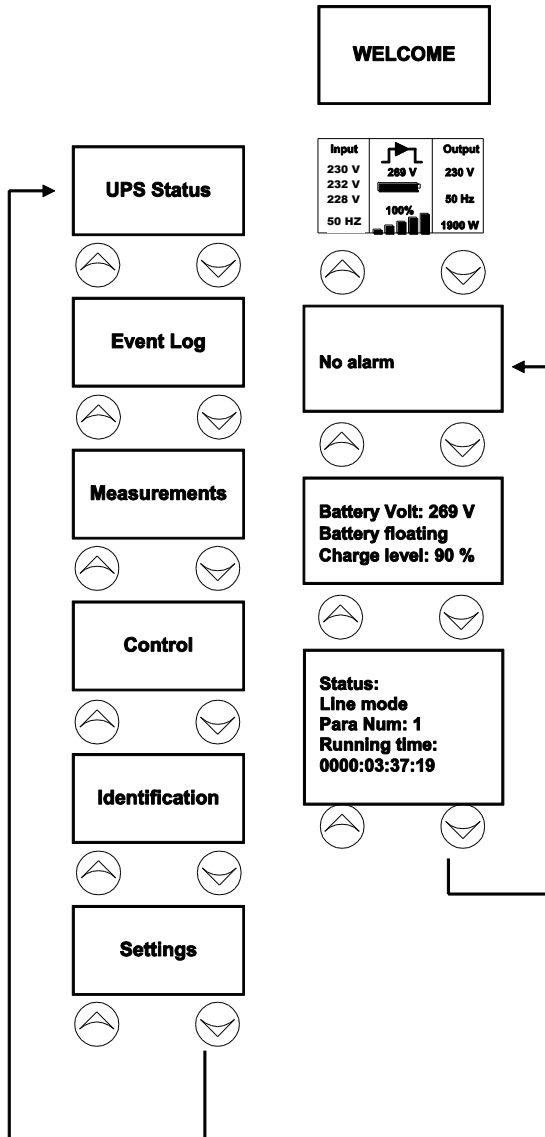





Fig. 7-12 Menu structure

Button	Description
	The description of this button can be found in <b>chapter 3.1.2 Buttons</b> .
	The description of this button can be found in <b>chapter 3.1.2 Buttons</b> .
	The description of this button can be found in <b>chapter 3.1.2 Buttons</b> .
	The description of this button can be found in <b>chapter 3.1.2 Buttons</b> .

Parameters	Description
Display "Alarm"	The status messages menu displays the latest error messages listed together with the count of the operating hours counter, the alarm code and the plain text of the error message.
Display "Battery voltage and Load Status"	The menu displays the condition of the battery.
Display "Status and Running time"	The menu displays the operating mode and the hours of operation of the UPS. The value Para Num shows how many devices are connected in parallel.

## 7.3 Menu

### 7.3.1 UPS status menu

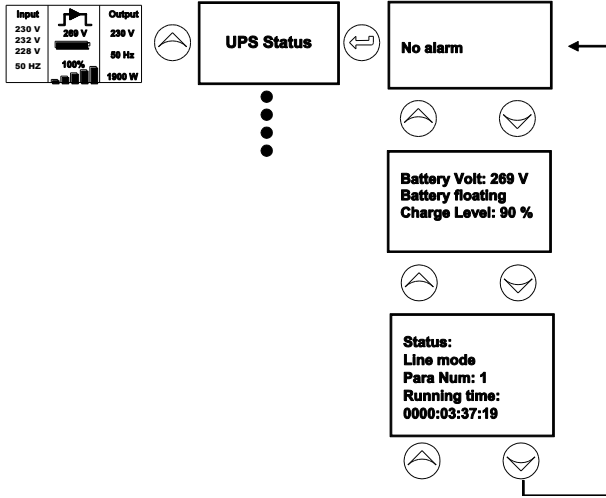

Fig. 7-13 UPS status menu

Parameters	Description
Display "Alarm"	The status messages menu displays the latest error messages listed together with the count of the operating hours counter, the alarm code and the plain text of the error message. For further details on fault warnings see chapter 8.
Display "Battery voltage and Load Status"	The menu displays the condition of the battery.
Display "Status and Running time"	The menu displays the operating mode and the hours of operation of the UPS. The value Para Num shows how many devices are connected in parallel.

### 7.3.2 Event Log Menu

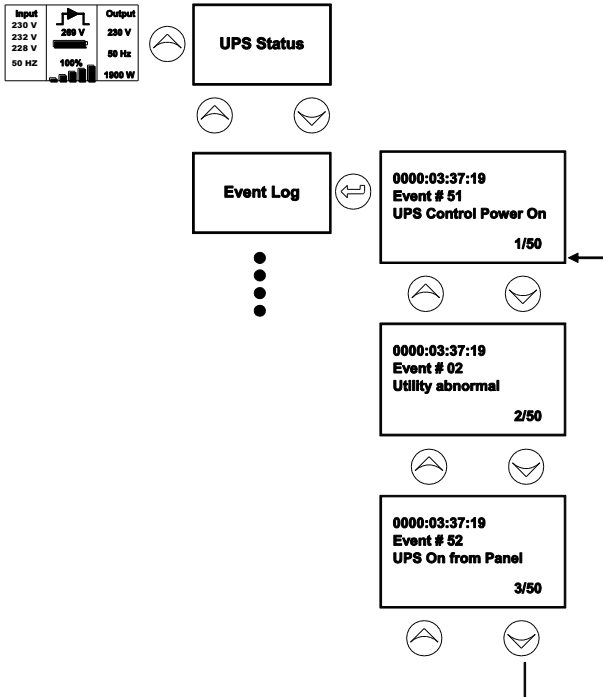

Fig. 7-14 Event Log Menu

Parameters	Description
Display "Event Log"	The menu displays up to 50 warning / fault messages and results. In the event of more than 50 entries, the old entries will be over-written.

### 7.3.3 Measurements Menu

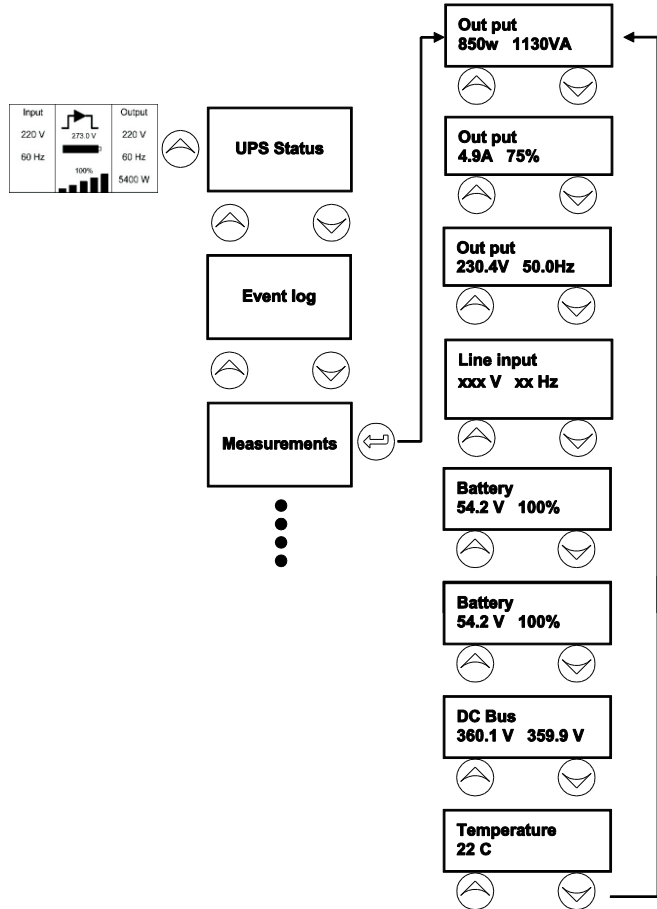

Fig. 7-15 Measurements Menu



Parameters	Description
Display "Output"	Displays the power output of the UPS. Left value = active power Right value = apparent power
Display "Output"	Displays the output current of the UPS. Left value = output current Right value = output current in % percent
Display "Output"	Displays the output voltage of the UPS. Left value = output voltage Right value = output frequency
Display "Input"	Displays the input phases.
Display "Battery"	Displays the battery voltage and the charging status of the UPS.
Display "DC Bus"	Displays the DC bus voltage of the UPS.
Display "Temperature"	Displays the temperature of the UPS.

7.3.4 Control Menu

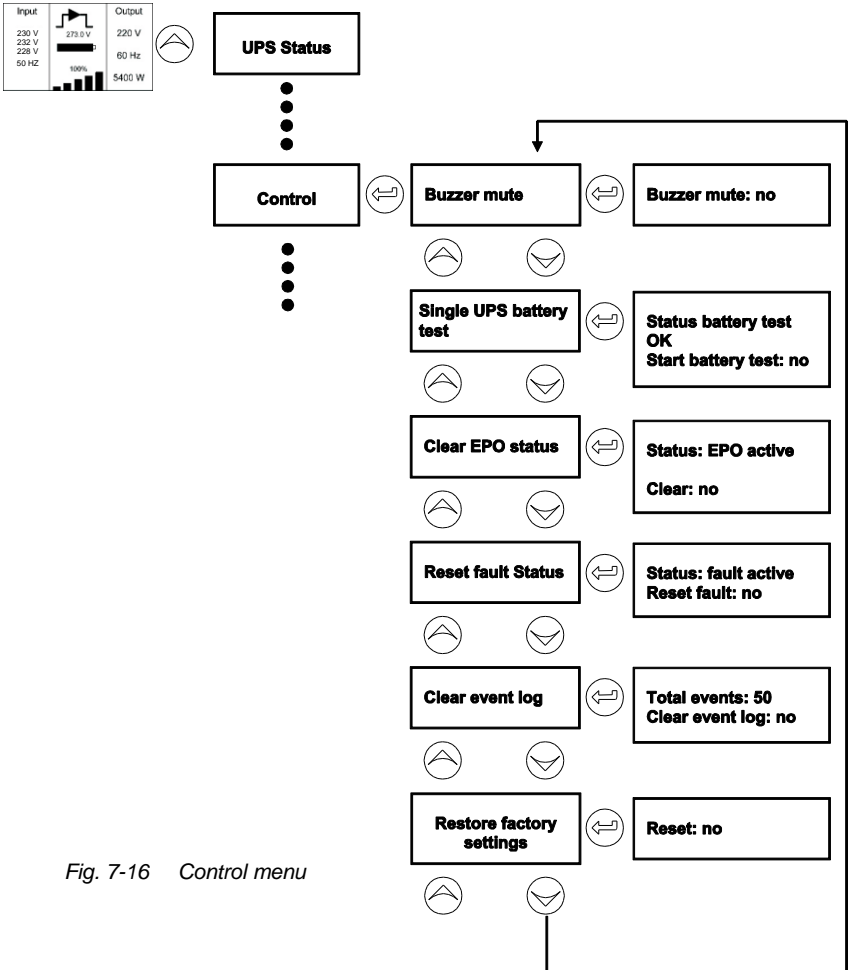

Fig. 7-16 Control menu

Menu	Parameters	Settings	Factory setting
Buzzer mute	Buzzer mute	<No><Yes> No: The keypad tones of the UPS are turned on. Yes: The keypad tones of the UPS are turned off.	No
Single UPS battery test	Status battery test	The status of the latest battery tests is displayed here.	
	Start battery test	<No><Yes> No: No battery test is performed. Yes: A battery test is performed. You can configure the cycle for a battery test in the menu "automatic battery test period". ★ chapter 7.3.6 Settings Menu	No
Clear EPO status	Status	Displays the EPO-status.	
	Clear	<No><Yes> No: If the EPO had been triggered, it will <b>not</b> be reset. Yes: If the EPO had been triggered, it will be reset.	No
Reset fault status	Status	Displays whether the fault mode is active or inactive.	
	Reset fault	<No><Yes> No: If a fault is pending on the UPS, it will <b>not</b> be reset. Yes: If a fault is pending on the UPS, it will be reset.	No
Clear event log	Total events	Displays the number of messages.	

	Clear event log	<p>&lt;No&gt;&lt;Yes&gt;</p> <p>No: The warning / fault messages have <b>not</b> been reset.</p> <p>Yes: The warning / fault messages have been deleted.</p>	No
Restore factory settings	Reset	<p>&lt;No&gt;&lt;Yes&gt;</p> <p>No: The UPS will <b>not</b> be reset to factory settings.</p> <p>Yes: The UPS will be reset to factory settings.</p>	No

### 7.3.5 Identification Menu

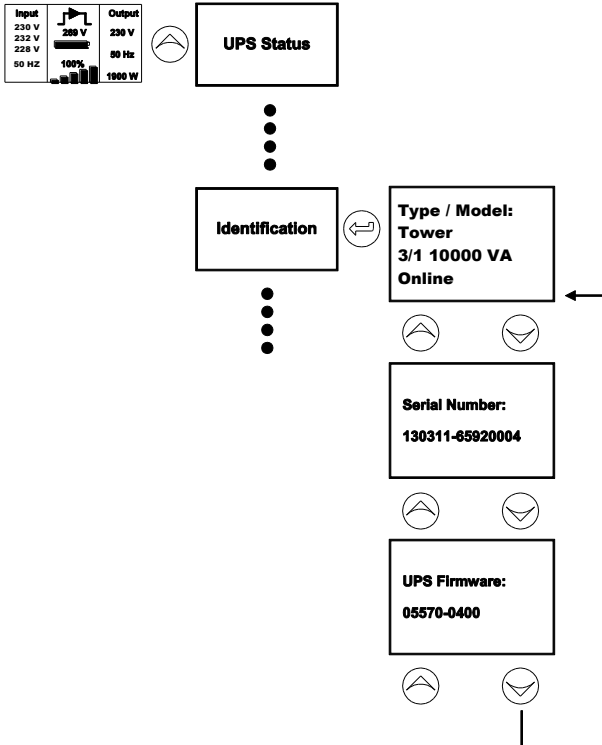
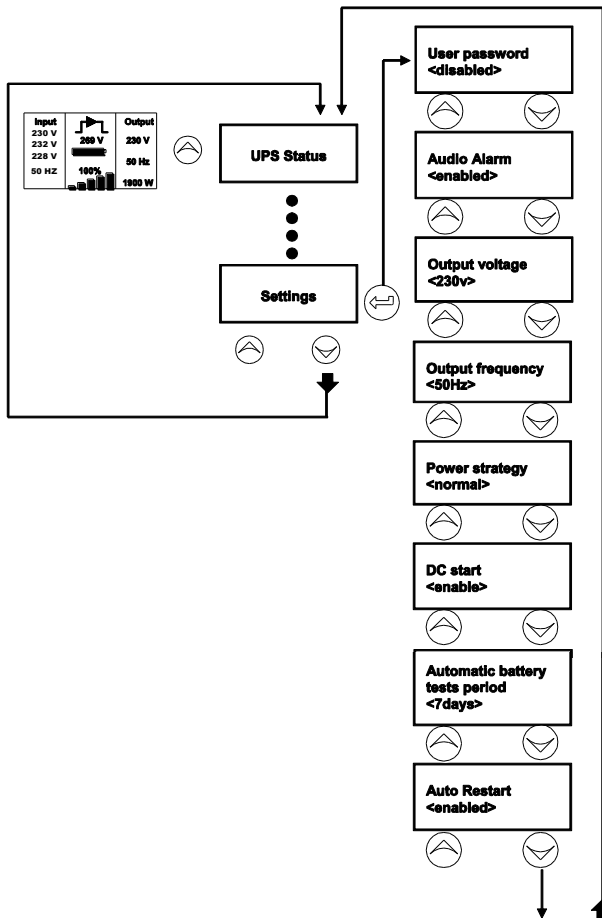

Fig. 7-17 Identification Menu

Parameters	Description
Display "Type / Model"	Displays the UPS type / model.
Display "Serial number"	Displays the UPS's serial number.
Display "UPS firmware"	Displays the current UPS firmware.

### 7.3.6 Settings Menu



The menu structure is continued on the next page.

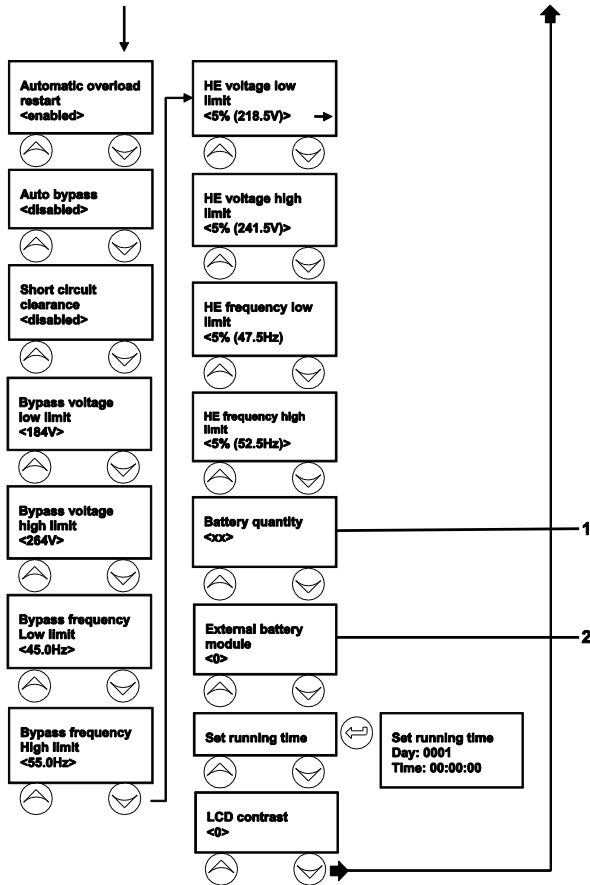

- 1 Only for models 6kVA and 10 kVA
- 2 Only for models 6kVA XL and 10kVA XL

Fig. 7-18 Settings Menu

Parameters	Settings	Default value
User password	<enable><disable> If this value is set to <enable>, you have to enter the password.	disable
Audio alarm	<enable><disable> If this value is set to <disable>, the UPS is silent and no alarm signals will sound.	enable
Output voltage	<208><220><230><240>	230V
Output frequency	<50HZ><60HZ> < Autosensing> On <autosensing> the output frequency is identical to the input frequency.	autosensing
Power strategy	<normal> <high efficiency> <converter>	Normal
DC start	<enable><disable> cold boot	enable
Site wiring alarm	<enable><disable> If this value is set to <enable>, a warning message appears in the display, when the protective earth conductor is not connected or if phase and neutral have been swapped.	enabled
Ambient temperature warning	<enable><disable> If this value is set to <enable>, a warning message appears in the display when the ambient temperature reaches 45°C.	enabled
Automatic battery tests period	<0>....<31days> If this value is "0", the automatic battery test is turned off.	7 days
Auto restart	<enable><disable> <enable> means that the UPS performs an automatic restart in normal operating mode, if it was shut down due to a low battery charge status.	enable
Automatic overload restart	<enable><disable> <enable> signifies that the UPS switches from bypass to line mode after the batteries have been charged to 70 %.	enable



Auto bypass	<p>&lt;enable&gt;&lt;disable&gt;</p> <p>&lt;enable&gt; signifies that the UPS switches to bypass mode after start up.</p> <p>&lt;disable&gt; signifies that the UPS does not start in bypass mode, but switches to bypass mode if a fault is detected or the batteries are overloaded.</p>	disable
Short circuit clearance	<p>&lt;enable&gt;&lt;disable&gt;</p> <p>&lt;enable&gt; means the UPS stays in line mode and no warning message is displayed if a short circuit at the output last less than four seconds.</p> <p>&lt;disable&gt; means that the UPS switches to fault mode and displays a warning signal if a short circuit at the output lasts more than four seconds.</p>	disable
Bypass voltage low limit	<167V>....<215V>	176V
Bypass frequency high limit	<+1%(50.5HZ)>....<+10%(55.0HZ)>	10%
Bypass voltage high limit	<245V>....<276V>	264V
Bypass frequency low limit	<-10%(45.0HZ)>....<-1%(49.5HZ)>	10%
HE voltage low limit	<-10%(207.0V)>....<-0,5%(218.5V)	5%
HE voltage high limit	<+5%(241.5V)>....<+10%(253.0V)>	5%
HE frequency low limit	<-10%(45.0HZ)>....<-1%(49.5HZ)>	5%
HE frequency high limit	<+1%(50.5HZ)>....<+10%(55.0HZ)>	5%
Battery quantity	<p>&lt;19&gt;....&lt;21&gt;</p> <p>Displays the number of internal, integrated accumulators.</p>	20
External battery module	<p>&lt;0&gt;....&lt;9&gt;</p> <p>The selected value gives the number of external battery modules.</p>	0
Set running time	<p>Day:0000-9999</p> <p>Hour:00-23</p> <p>Minute:00-59</p> <p>Second:00-59</p>	Running Time
LCD contrast	<p>&lt;-5&gt;....&lt;+5&gt;</p> <p>The contrast of the LCD-Display can be adjusted here between – 5 and + 5.</p>	0

## 8. Troubleshooting

If the UPS system does not operate correctly, first check the operating information on the LCD display.

Please attempt to solve the problem using the table below. If the problem still persists, consult your dealer.

### 8.1 Troubleshooting according to warning indication

Error code	Name	Solution
Error code: 01	Bus short (bus error– short circuit)	Please contact your dealer or the customer service.
Error code: 02	Bus voltage over (bus error – overvoltage)	Please contact your dealer or the customer service.
Error code: 03	BUS voltage low (bus error – low voltage)	Please contact your dealer or the customer service.
Error code: 04	BUS voltage Unbalance (bus error – unbalances voltage)	Please contact your dealer or the customer service.
Error code: 05	BUS soft-start Fail (bus soft-start failure)	Please contact your dealer or the customer service.
Error code: 06	Inverter soft-start fail (inverter soft-start failure)	Please contact your dealer or the customer service.
Error code: 07	Inverter short (inverter short circuit)	Remove all the loads. Turn off the UPS. Ensure that the load has not failed and that there are no internal UPS failures / errors, before you turn it back on. If this does not solve the issue, please contact your dealer or the customer service.
Error code: 08	Inverter voltage low (inverter voltage low)	Please contact your dealer or the customer service.
Error code: 09	Inverter voltage high (inverter voltage high)	Please contact your dealer or the customer service.
Error code: 10	Inverter Relay short (inverter relay short circuit)	Please contact your dealer or the customer service.
Error code: 11	Overload Fault	Check the loads and remove the

		non-critical equipment. Calculate the load current again and reduce the number of loads that are connected to the UPS. Check if any of the loads failed.
Error code: 12	PARA Communication Line loss Fault	Make sure the parallel port is correctly and fully connected. If this does not solve the issue, please contact your dealer or the customer service.
Error code: 13	Null(reservation)	
Error code: 14	Negative power Fault	Please contact your dealer or the customer service.
Error code: 15	Over Temperature	Ensure that the USP does not have an overload; that the ventilation openings are not blocked, and that the ambient temperature is not too high. Wait 10 minutes to allow for the UPS to cool, before restarting it. If this does not solve the issue, please contact your dealer or the customer service.
Error code: 16	Model set fault	Please contact your dealer or the customer service.
Error code: 17	Backfeeder	Do not touch any of the connections of the device that connect the UPS with the mains power supply, even after you have turned off the power supply or disconnected the device. Please contact your dealer or the customer service.
Error code: 18	Parallel Single communication Line loss Fault	Make sure the parallel port is correctly and fully connected. If this does not solve the issue, please contact your dealer or the customer service.
Error code: 19	CAN Communication fault	Make sure the parallel port is

		<p>correctly and fully connected. If this does not solve the issue, please contact your dealer or the customer service.</p>
--	--	---

When you contact the service centre, please provide the following information:

- Model number, serial number.
- Date on which the problem occurred.
- LCD/LED display information, Buzzer alarm status
- Mains power condition, load type and capacity, environment temperature, ventilation condition.
- Information (battery capacity, number) about the external battery pack, if it is a UPS of the model series "XL".
- Any additional information for a complete description of the problem.

## 9. Software

With a suitable software package the configurations and operating statuses of the UPS can be determined and processed via the communication interface.

The software packages are available from the manufacturer / dealer or through the service hotline. Through these channels you can receive useful information about the suitable software packages for your UPS to fit your needs.

See also our website:

<http://www. effekta.com/>

The following basic functions are supported by all software packages:

- Detecting and displaying the UPS's power supply status
- Display of the UPS output status
- Detecting and displaying the charging status of the battery bank.
- Closing of open applications in the case of a mains failure.
- Shut down of the operating system.
- Creating log files.
- Basic monitoring of UPS-data and condition (diagnostic function).

For more information on the individual software packages, like installation, operation and range of services, see the respective software manuals.



---

In the chapter "Scope of Delivery / (Optional) Accessories" you will find suitable and tested software packages.

---

## 10. Maintenance and Service

You may expect a long service life and interference-free operation of your UPS at a minimum of maintenance effort.

However, the reliability of the UPS is greatly dependant on the ambient conditions. The ambient temperature and humidity must remain within the given range. In addition, the area around the UPS should be kept clean and free of dust.

At an ideal ambient temperature of about 22°C, the service life of the accumulators is typically around 4 years. Through the use of special accumulators the service life can be significantly increased (about 8-10 years).

You should check periodically (every 6 - 12 months) whether the remaining backup time is sufficient for the intended purposes. Once that is no longer the case, the accumulators have to be replaced.

### 10.1 Measuring the backup-time (support time)

---

## WARNING!

Before you begin this procedure, please make sure to save all open data. Furthermore, inform all affected employees.

Basically there are two different methods for measuring the back-up time.

Method a)

measures the actual back-up time, which means that at the end of that backup time the appliances would be without a power supply.

Method b)

allows to determine the residual capacity after a defined backup-period. In this case the appliances will usually not be without power in the end.

To use either method, you have to force the UPS into backup mode, by simulating a mains failure (e.g. trip the fuse of the building). Do not, under any circumstances, remove the mains connection, as that would also disconnect the protective earth conductor. After the measurement has been carried out, turn the circuit breaker back on and turn on the UPS as usual, with the ON-button.

---



---

Remember that after the measuring the accumulators of the system will be discharged. I.e. the UPS-system must operate in line mode or charging mode respectively for several hours (min. 5 h), before it will again be operational at about 80% capacity.

---

If the backup time is not measured due to local conditions or instructions, we recommend a prophylactic replacement of the accumulators every two years, to avoid any risk of insufficient backup time because of degenerated accumulators.

## 10.2 Replacing the accumulators

Accumulators may only be replaced by the manufacturer.

### 10.3 Service-Log

Please always enter all maintenance and service work conducted on the UPS into the service-log.

Date	Performed tasks	Performed by



## 10.4 Service-Hotline

If unexpected problems occur with the photovoltaic solar inverter or you need safety information, please contact our service hotline by phone or fax:

Phone: 0049 / (0) 741 – 17451-52  
Fax: 0049 / (0) 741 – 17451-29

If you cannot reach us by phone or fax, we have set up an e-mail contact for you:

ups@effekta.com

In addition you can contact the central area or branch office directly as listed on our website:

<http://www.effekta.com/html/kontakt.html>

## 10.5 Maintenance and service contracts

**EFFEKTA Regeltechnik GmbH** offers the related maintenance services to ensure the highest possible reliability and availability of the UPS-system. In addition, we offer maintenance contracts to support and assist you in the following areas with our qualified staff:



Regular testing of the equipment, in particular the accumulators, as well as timely replacement and proper disposal of accumulators.



Inspection of the UPS-installation.



Proper disposal of defective or degenerated components.

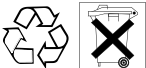

Environmentally acceptable disposal of accumulators.

You can find the complete range of our services on-line at:

<http://www.effekta.com/html/service.html>

or contact us directly at the addresses given above.

## 11. Technical Data

Input		
Model	10kVA	20kVA
Phase	3 to 1	
Voltage	176~276VAC	
Frequency	50/60 Hz $\pm$ 10%	
Current	L1/L2/L3: 18,1A Max	L1/L2/L3: 36,3A Max
THDI	<5% at full load	
Performance factor	>0.99 @ at full load	

Output		
Model	10kVA	20kVA
Connected load	10kVA/9kW	20kVA/18kW
Voltage	200/208/220/230/240VAC*	
Current	45A/48,1A/45,5A/43,5A/41,7A	90A/96,2A/90,9A/87A/83,3A
Frequency	50/60Hz $\pm$ 10% in line mode 50/60Hz $\pm$ 0,1% of the normal frequency in battery mode	
Wave form	sine wave	
THDV	< 2% @ full linear load <5% @ full non linear load	
Overload	In Line mode**: 10 min 105~125% 1 min 125~150% 10 s >150% 100 ms >170% In Battery mode: 2 min 105~125% 30 s 125~150% 100 ms >150%	

\*The load capacity is limited to 90% automatically, if the output voltage is set at 200 VAC.

Battery banks		
Model	10kVA	20kVA
Voltage	288VDC	
Type and number of batteries	24x 12V 9Ah	2x24x 12V 9Ah
Charging rate of a battery pack	33,6A	67,2A



Environment									
Storage temperature	-15°C – 50°C								
Operating environment	Operating temperature					0°C – 40°C			
	Humidity					< 95 % (without condensation)			
Altitude (m)	1000	1500	2000	2500	3000	3500	4000	4500	5000
Maximum performance	100%	95%	91%	86%	82%	78%	74%	70%	67%

Standards	
Safety	EN 62040-1:2008
EMV	EN 62040-2:2006

## 12. Scope of Delivery / (Optional) Accessories

Below you find a list of components that have been approved and tested by **EF-FEKTA Regeltechnik GmbH** especially for this UPS (Please check the delivery for completeness immediately after receiving the goods).

### 12.1.1 Scope of Delivery Adira

No	Description	Function / View:	Article number	Scope of delivery
1 x	UPS electronics incl. internal batteries		Adira 10 kVA 3/1 ph ACX31ADS10K00000	
1 x	UPS electronics incl. internal batteries		Adira 20 kVA 3/1 ph ACX31ADS20K00000	
1 x	Battery banks for USV 10 & 20 kVA 3/1 ph		Battery Bank <b>With 24 accumulators:</b> ABADX124009XXK00 <b>With 2 x 24 accumulators:</b> ABADX224009XXK00	
1 x	Operating Manual	<b>Printed Operating Manual - English</b>		X
1 x	USB cable	Interface connection		X

	Software package "PowerShut Plus"	CD-ROM network compatible shut-down and diagnosis software 1 license Windows/Novell 1 license UNIX, LINUX, MAC 1 license RCCMD (network remote client)	LAN-PowerShut	X
--	-----------------------------------	---	---------------	---

**12.1.2 Communication interfaces (optional accessories)**

Description	Article number	Type
SNMP-card	GE/cs121-SLBdget	Internal SNMP-adapter budget version

**12.2 Wearing parts list**

The following list of components are related to regular wear and are therefore not subject to the warranty of the UPS:

Wearing part	Function	Article number
XXXX XX XX ** Accumulator (Battery) 12 V xx Ah	Energy storage	Depending on the assembly, see accessories or on request.

\*\* For the wear part description of the accumulators please see the assembled accumulators, or on contact us.

# 13. Conformity Declarations

## 13.1 Adira 3/1 10kVA

**EFFEKTA®**

**EC-Declaration of Conformity**

**Address:** EFFEKTA Regeltechnik GmbH  
Rheinwaldstr. 34  
D- 78628 Rottweil  
Germany

**Product description:** UNINTERRUPTIBLE POWER SYSTEMS

**Model:** ADIRA 3/1 10 kVA

The above mentioned product is in delivered condition compliant with the following guidelines:

2004/108/EC: Council directive on the approximation of the laws of the member states relating to electromagnetic compatibility.

2006/95/EC: Council directive on the approximation of the laws of the member states concerning electrical equipment for use within certain voltage limits.

The conformity with the guidelines is guaranteed under application of following standards:

Safety		Electromagnetic compatibility (EMC) Class C3	
Number	Issue	Number	Issue
EN62040-1	2006	EN62040-2	2006

Rottweil, 2014.03.07

  
.....  
( Peter Androt / Managing Director )

13.2 Adira 3/1 20kVA

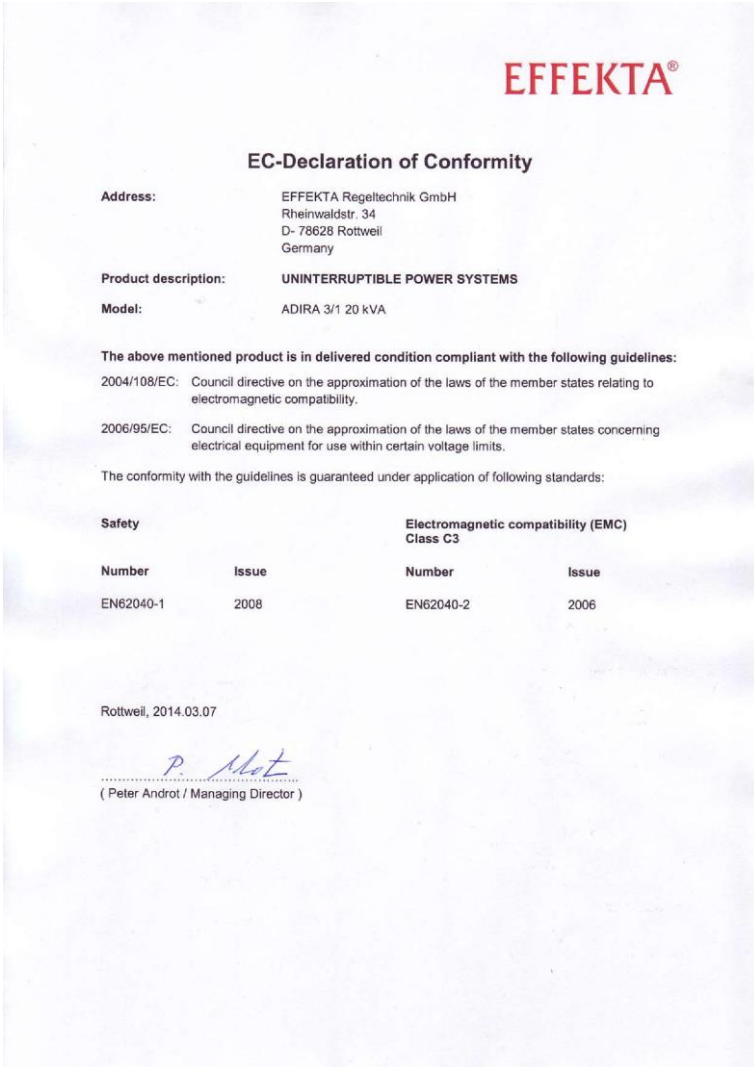

**EFFEKTA®**

EFFEKTA Regeltechnik GmbH

Rheinwaldstraße 34  
D – 78628 Rottweil